



STANDBY GENERATOR ACCESSORIES

RTS Automatic Transfer Switch

100 - 400 Amps 600 VAC



100 – 400 Amp RTS NEMA 3R

DESCRIPTION

Generac RTS automatic transfer switches are designed to operate with the digital control used on air-cooled generators and the Generac R100 control used on liquid-cooled QT series gaseous generators from 8 kW through 60 kW. The RTS transfer switch will operate only with the Generac R100 controller. The 100, 200 and 400 amp open transition switches are available in single and 3 phase configurations for 120/240, 120/208 and 120/240 3 phase at 100, 200 and 400 amp ratings and 277/480 at the 100 and 200 amp rating. It is available as a stand-alone switch or for single phase with a built in 8, 10, 12, 14 or 16-circuit load center to supply only those circuits that are essential during an emergency. All standard and load center transfer switches are UL and CUL Listed and suitable for use as optional standby systems (NEC702).

STANDARD FEATURES

All RTS transfer switches are housed in a steel NEMA 1 or aluminum NEMA 3R enclosure, with electrostatically applied and baked powder paint. The Heavy Duty Generac Contactor is a UL recognized device, designed for years of service. The control connection between the RTS and the Generator Control panel is through #14 wires. The control at the generator handles all the timing, sensing and exercising functions.



100 AMP TRANSFER SWITCH

This 100 amp Transfer switch has an integrated load center for picking up the emergency circuits. It is especially useful where the main service is large and only a portion of the building load will be served by the generator. Internal point to point wiring for the generator connection and the 8, 10, 12, 14 or 16 circuits and circuit breakers from the main distribution point are included.

SERVICE ENTRANCE RATED SWITCH

The Generac Service Entrance Rated Transfer Switches are available in 100, 200 and 400 amp ratings in single phase applications. The switches are UL 1008 listed with 100, 200 or 400 amp UL rated Circuit Breakers on both the Utility and Generator side of the transfer contactor for full downstream protection. The enclosure is rated for NEMA 3R installation and is fully protected from the elements.

FUNCTIONS

All Timing and sensing functions originate in the R-100 controller

Utility voltage drop-out.....	<60%
Timer to generator start	15 seconds
Engine warm up delay.....	10 seconds
Standby voltage sensor.....	90%
Utility voltage pickup.....	>80%
Re-transfer time delay.....	15 seconds
Engine cool-down timer.....	60 seconds
Exerciser	15 minutes every 7 days

The transfer switch can be operated manually without power applied.

SPECIFICATIONS

Amps	100	100	100	200	200	400	400
Voltage	120/240, 1Ø	120/240, 1Ø 120/208, 3Ø 277/480, 3Ø	120/240, 1Ø	120/240, 1Ø 120/208, 3Ø 277/480, 3Ø	120/240, 1Ø	120/240, 1Ø 120/208, 3Ø	120/240, 1Ø
Load Transition Type (Automatic)	Open Transition w/ 8, 10, 12, 14 or 16 Cir. Load Center	Open Transition	Open Transition Ser. Ent. Rated	Open Transition	Open Transition Ser. Ent. Rated	Open Transition	Open Transition Ser. Ent. Rated
Enclosure Type	NEMA 1	NEMA 3R	NEMA 3R	NEMA 3R	NEMA 3R	NEMA 3R	NEMA 3R
Express Install Kit Included	Yes	No	No	No	No	No	No
Withstand Rating (Amps)	10,000	10,000	10,000	10,000	10,000	18,000	18,000
Lug Range	2/0 - #14		400 MCM - #4		600 MCM - #4 or 2-250 MCM		
External Dimensions (H" x W" x D")	27 x 13 x 7	20 x 15.2 x 7.3 24.1 x 20.5 x 7.3 24.1 x 20.5 x 7.3 36.1 x 24.4 x 10.2	20 x 15.2 x 7.3	20 x 15.2 x 7.3 24.1 x 20.5 x 7.3 24.1 x 20.5 x 7.3 48.1 x 30.6 x 13.3	30 x 16.5 x 7.3	36.1 x 24.38 x 10.2 36.1 x 24.38 x 10.2 36.1 x 24.38 x 10.2	40 x 30.8 x 10.5
Unit Weight (lbs.)	30	26	42	48	50	95	105

TYPICAL CONNECTION

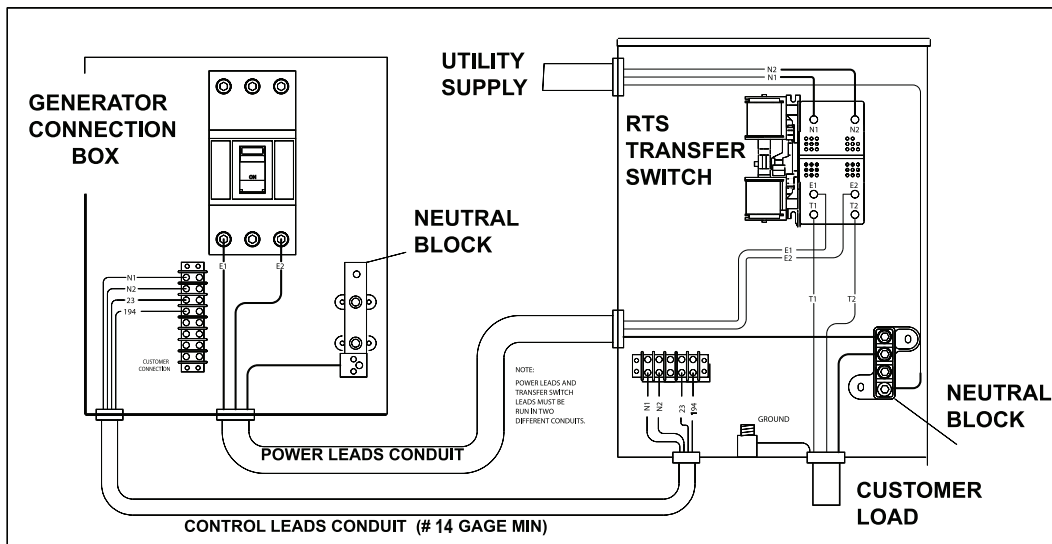

*100 Amp, NEMA 1 Switch Not Shown



Generac Power Systems, Inc. • P.O. Box 297, Whitewater, WI 53190 • guardiangenerators.com

©2008 Generac Power Systems, Inc. All rights reserved. All specifications are subject to change without notice. Bulletin 0178010SBY/Printed in U.S.A. 05.08, rev: 06.08